

## Cockatoo Multi-Purpose IoT RTU

Versatile Transmitter for  
IoT Sensors



### Key Features

- Supports a range of common commercial and industrial protocols, enabling a variety range of sensors to be easily deployed
- Supported interfaces include Pulse, Modbus over RS232/RS485, SDI-12 and 4-20mA.
- Flexibility in radio options - Taggle Byron, NB-IoT and Myriota Satellite
- Support for both internal and external antenna configurations
- NFC Programming Port for rapid infield device installation and configuration
- Flexible power supply options include 1-4 field replaceable internal D-cell batteries or any 9-30V external DC power source
- IP68 rating provides high degree of protection against ingress of dust and moisture
- Corrosion resistant stainless steel connectors enabling deployment in hazardous environments such as sewers
- Suitable for both urban and rural deployments
- Transmissions are secured with AES 128 encryption (AES 256 for satellite solution)

The Cockatoo is Taggle's most versatile telemetry device with the flexibility to accommodate a range of sensors, protocols and radio technologies to address uncommon or specific requirements and challenges.

The Cockatoo is designed to interface to a range of analog and digital sensors widely used in industrial automation and environmental monitoring applications.

Supported interfaces include Pulse, Modbus over RS232/RS485, SDI-12 and 4-20mA.

Applications include level, pressure,

flow, water and air quality, weather, odour and gas.

The Cockatoo can be configured to transmit over different radio technologies to best suit an application or location including the Taggle Byron Radio, NB-IoT and Myriota Satellite.

The Cockatoo is fitted with NFC allowing for rapid infield

installation and configuration, configuration adjustments and firmware updates.

Modular hardware allows for flexible, efficient, manufacturing options. The Cockatoo holds up to four D-cell batteries which are replaceable or can be externally powered from any 9-30V external power source.

## Technical Details

Dimensions	213mm (L) x 96mm (D)
Weight (approx)	Varies dependent on configuration and number of batteries fitted
Enclosure Material	Ultradur PBT
Ingress Protection	Hermetically sealed; IP68
Temperature	-10°C to 60°C (Average temperature not to exceed 30°C)

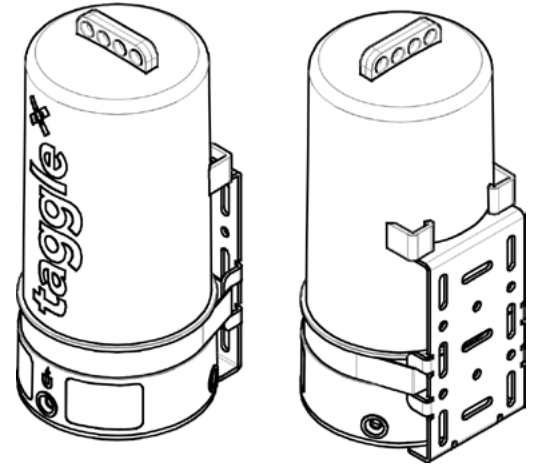

## Battery

Type/Size	Up to 4 x 3.6 V Lithium Thionyl Chloride D-cell (Field Replaceable)
Battery life	Varies dependent on application, configuration and number of batteries fitted



## Sensing/Inputs

Input Types	Pulse, Modbus over RS232/RS485, SDI-12, 4-20mA.
Connectors	- Stainless steel M12 sensor connector - Optional stainless steel M12 external power connector - Optional stainless steel SMA external antenna connector



## Sensor Compatibility

The Cockatoo is compatible with a wide range of sensor and water meter types allowing for use in many industrial and environmental applications.

## Applications

- Level
- Pressure
- Weather
- Flow
- Water and Air Quality
- Odour
- Gas

## Communications

The Cockatoo offers flexibility of radio choice allowing the best solution to be utilised for the application in question.

The Taggle Byron Radio comes as standard within the Cockatoo however, NB-IoT would be implemented where two-way communication is required, and satellite would best suit rural deployments of small numbers, spread out over large distances, where the cost of rolling out a Taggle Byron network would not be justified.

## Taggle Byron Radio

ASIC	Taggle Byron A31
Operating Frequency/Band	915-928MHz LIPD band in Australia 902-928MHz ISM band in USA
Signal Type	Direct Sequence Spread Spectrum
Communication Type	One-Way Communication
Operating Range	~2-5km Urban ~5-50km Rural (Dependent on local installation conditions)
Security	AES 128 encryption
Power	500 mW

## Satellite Solution

ASIC	Myriota Satellite Module
Operating Band	VHF/UHF - Australia
Latency	Coverage windows every 2 to 3 hours
Transmission	Uplink 20 bytes per payload per message
Communication Type	One-Way Communication
Operating Range	Australia Wide (Line of sight to satellite)
Security	AES-CBC-256



## Near Field Communication (NFC)

NFC allows configuration adjustments such as the transmission interval post activation and firmware updates in the field.

Easy activation and configuration when the device is installed.

NFC allows retrieval of diagnostic information and data logs even after a power failure.

## History of the Cockatoo

The Cockatoo is the second generation of the Taggle LSTT Communication Module, which has been in successful deployment across Australia since 2016.

The LSTT has been used in monitoring sewer networks, environmental sensing, pressure within the reticulation network and many other varied applications.

### Australian Office

Level 1, 101 Sussex Street  
Sydney NSW 2000  
enquiries@taggle.com.au  
+61 2 8999 1919

### USA Office

PO Box 40519 San Francisco  
CA 94140-0519  
enquiries@taggle.com  
USA Toll Free: 800 619 2919

### License and Certification

ACMA LIPD Class License  
FCC Part 15.247

© Copyright 2020 Taggle Systems Pty LTD All Rights Reserved.  
The information contained in this document is subject to change without notice.  
Taggle Systems shall not be liable for any errors contained herein.

COC.ST.002